

Smart Function Kit
for pressing and joining applications

R320103194/2026-04
EN

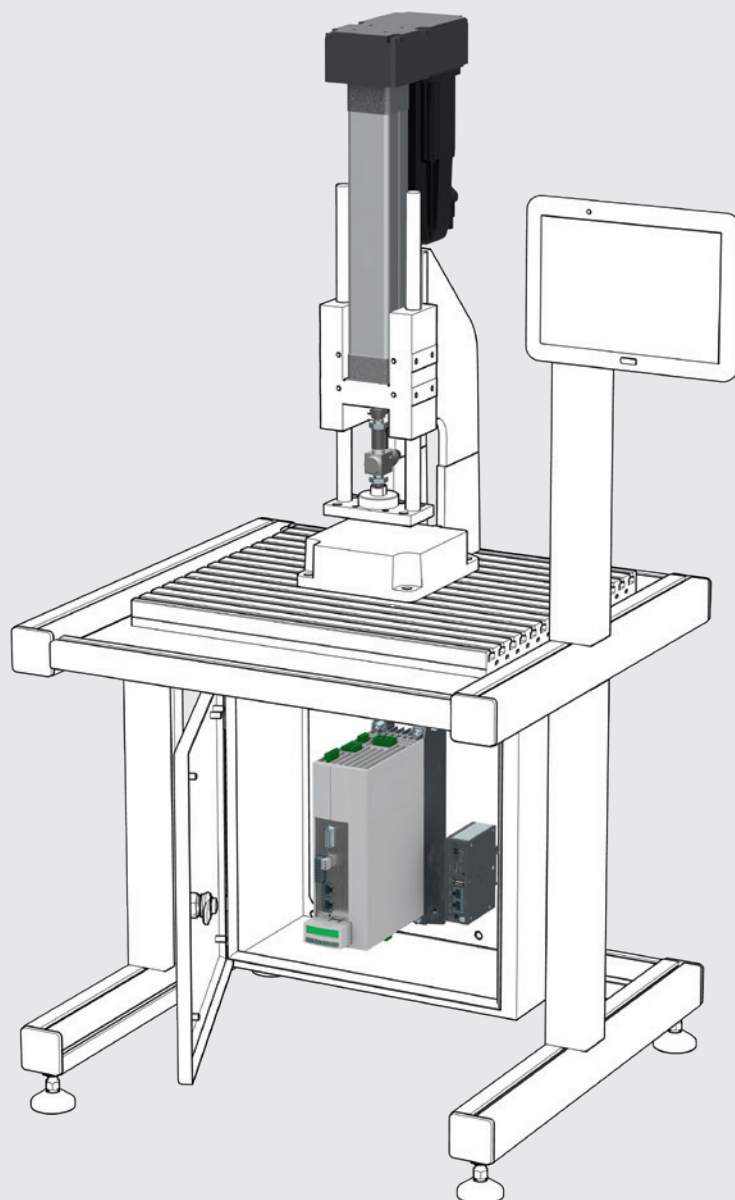

Instructions



The data specified above only serves to describe the product. No statements concerning a certain condition or suitability for a certain purpose can be derived from our information. The information given does not release the user from the obligation of own judgment and verification. Please note that our products are subject to a natural process of wear and aging.

© This document, as well as the data, specifications, and other information set forth in it, are the exclusive property of Bosch Rexroth AG. It may not be reproduced or given to third parties without our consent.

The title page contains an illustration of a sample configuration. The product as delivered can differ from the illustration. The original instructions are in German.

Any dissemination of the product must include these mounting instructions and the safety instructions and information for linear motion systems R320103152.

These instructions are available in the following languages.

DE German (Original document)

EN English

Contents

1	About this documentation	4
1.1	Validity of the documentation	4
1.2	Required and supplementary documentation	4
1.3	Presentation of information	4
2	Safety instructions	5
2.1	Intended use	6
2.2	Misuse	6
3	Scope of delivery	6
3.1	Delivery condition	6
3.2	Accessories	6
4	Product description	6
4.1	Performance description	6
4.2	Device description	7
4.3	Product identification	7
5	Transport and storage	8
5.1	Transporting the Smart Function Kit	8
5.2	Storing the Smart Function Kit	8
6	Assembly	9
6.1	Installation conditions	9
6.2	Installation position	10
6.3	Required accessories	10
6.4	Fastening options	10
6.5	Mounting the force sensor	11
6.6	Mounting the EMC	12
6.7	Connecting the electrical power supply to the EMC	12
6.8	Connecting the fan unit	13
7	Installation	14
7.1	General installation instructions	14
7.2	Installation of the HCS01 drive controller	15
7.3	Installation of the HSZ01 safety zone module with S4 safety option	22
7.4	Installation of the industrial PC PR21	27
7.5	Installation of the force sensor	28
7.6	Connection of the HMI terminal device	28
7.7	Connection of a higher-level controller	29
7.8	Connection to the IT infrastructure	29
8	Commissioning / operation	30
8.1	Checking the operating conditions	31
8.2	Commissioning (trial run, running in)	31
8.3	Operation	31
9	Maintenance and care	31
9.1	Cleaning and care	31
9.2	Regular maintenance work	31
9.3	CMOS battery industrial PC PR21	31
9.4	Maintenance of the force sensor	32
9.5	Lubrication of the electromechanical cylinder EMC	32
10	Disposal	34
10.1	Return	34
10.2	Packaging	34
10.3	Product	34
10.4	Batteries and accumulators	34
10.5	Recycling	34
11	Service and support	35
12	Operating conditions	36
12.1	Tightening torques	36

1 About this documentation

1.1 Validity of the documentation

This documentation applies to the following products:

- Smart Function Kit according to the "Smart Function Kit" online catalog.

This documentation is intended for assemblers, installers, operators, service technicians and system owners.

This documentation contains important information for proper and safe installation, transport, and maintenance of the product.

- ▶ This documentation, especially the chapter "Safety instructions", is to be read completely before working with the product.

1.2 Required and supplementary documentation

















- ▶ Only commission the product once you have obtained the system documentation that is marked with the  and understood and complied with its contents.

Table 1: Required documentation

	Title	Document number	Document type	Included in delivery
	Safety instructions for linear motion systems	R320103152	Safety instructions	✓
	Electromechanical cylinders EMC	R999000473	Catalog	
	Electromechanical cylinders EMC	R320103102	Instructions	✓
	Electromechanical cylinders EMC-HP	R999002086	Catalog	
	Electromechanical cylinders EMC-HP	R320103219	Instructions	✓
	IndraDrive HCS01 drive control units power units	R911339011	Instructions	
	IndraDrive drive components	R911337777	Safety instructions	✓
	IndraControl PR21	R911389663	Instructions	
	Safety and warning notice on control components	R911171137	Safety instructions	✓
	Motor MS2N	R911340694	Safety instructions	✓
	SMC	R911343864	Manual	
	Force sensor		Instructions	✓
	Smart Function Kit software	R320103208	Instructions	
	Smart Function Kit - Field bus	R320103209	Instructions	
	Smart Function Kit - OPC-UA + REST-API	R320103210	Instructions	

The Rexroth documentation is available for download at www.boschrexroth.com/mediadirectory.

1.3 Presentation of information

To enable users to work rapidly and safely with the product while following these instructions, this documentation uses standardized safety instructions, symbols, terms and definitions, and abbreviations. These are explained in the following sections.

1.3.1 Safety instructions in this document

This documentation contains safety instructions regarding any actions that involve a risk of personal injury or damage to property. The safety precautions described must be adhered to.

Safety instructions are structured as follows:



 SIGNAL WORD
<p>Type and source of hazard! Consequences if ignored.</p> <p>▶ Hazard prevention measure.</p>

Warning sign: draws attention to the hazard

- **Signal word:** indicates the severity of the hazard
- **Type and source of hazard:** indicates the type or source of the hazard
- **Consequences:** describes the consequences that may occur if precautions to avoid the hazard are not taken
- **Hazard prevention measure:** indicates how to avoid the hazard

The safety instructions cover the following hazard classes. The hazard class describes the risks involved if the safety instruction is not complied with.





Table 2: Hazard classes according to ANSI Z535.6

Warning sign, signal word	Meaning
 DANGER	Indicates a hazardous situation which will result in death or serious injury if not avoided.
 WARNING	Indicates a hazardous situation which may result in death or serious injury if not avoided.
 CAUTION	Indicates a hazardous situation which may result in minor or moderate injury if not avoided.
NOTICE	Property damage: The product or surroundings may be damaged

1.3.2 Symbols

The following symbols indicate notes which are not related to safety but make the documentation easier to understand.

Table 3: Meaning of the symbols

Symbol	Meaning
	If this information is not observed, the product will not be optimally used / operated.
w	Single, independent work step
1.	Numbered work steps The numbers indicate the sequence of the work steps.
2.	
3.	
→ 7	See section 7
→  Fig. 7.1	See figure 7.1
	Screw with strength class ...
	Tightening torque
μ	Friction factor for screws

1.3.3 Abbreviations

The following abbreviations are used in this documentation:

Table 4: Abbreviations and definitions

Abbreviation	Meaning
EMC	E lectro M echanical C ylinder
HCS01	Drive controller
HMI	H uman M achine I nterface (graphical user interface)
PR21	Industrial PC

2 Safety instructions

The general safety instructions for this product can be found in the documentation "Safety instructions for linear motion systems", "Safety instructions for IndraDrive drive components" and "Safety instructions for control components". You must have read and understood these before handling the product. In contrast, the following notes apply to the present system.

2.1 Intended use

The Smart Function Kit for presses is an incomplete machine according to the EC Machinery Directive 2006/42/EC. The product may be used in accordance with the technical documentation for the following purposes:

- Establishing mechanical connections, e.g. riveting, clamping or tacking;
- Bending or folding by press brakes or folding machines;
- Straightening;
- Hot forming or cold massive forming;
- Compression of metal powder;
- Spot welding;
- Pipe bending

The type-specific load data from the relevant catalogs and the supplementary technical documents provided by our company must be considered in all cases. The product is exclusively intended for incorporation into a final machine or system or for assembling with other components to build a final machine or system. The product is intended exclusively for professional use and not for private use. Use for the intended purpose requires that you must have read and understood the product documentation completely, in particular the "Safety instructions".

2.2 Misuse

Use of the product in any other way than as described under "Intended use" is considered to be misuse and is therefore not permitted. The product may only be used in applications or environments constituting a danger to the health and life of persons if this use has been expressly specified and permitted in the product documentation.

Misuse of the product includes:

- the transport of persons;
- use in potentially explosive environments;
- use in direct contact with unpackaged food;
- the use in the application area of DIN EN ISO 16092-1/-2

Bosch Rexroth AG will not accept any liability for injury or damage caused by misuse of the product. The risks associated with any misuse of the product shall be borne by the user alone.

3 Scope of delivery

The following is included within the scope of delivery:

- Smart Function Kit with motor, drive controller and accessories
- Documents ➡ "Table 1: Required documentation" on page 4 that are indicated
- ▶ Upon receipt of the delivery, immediately check for completeness against the receipt and notify the carrier or Bosch Rexroth AG if any parts are missing.

3.1 Delivery condition

- Depends on order

3.2 Accessories

The following accessories are available:

- Fastening elements; Motor attachment (flange coupling, belt side drive); Force sensor; Cable; 24 V Power supply; Uninterruptible power supply UPS; Extensions of the control and drive components; Isolating transformer and mains filter; Panel PC VR; CMOS battery for Industrial PC PR21



Dimensions and material numbers of the accessory parts as well as additional accessories ➡ Product catalogs.

4 Product description

4.1 Performance description

Please refer to the notes, technical data, dimensions and descriptions in the product catalog.

4.3 Device description

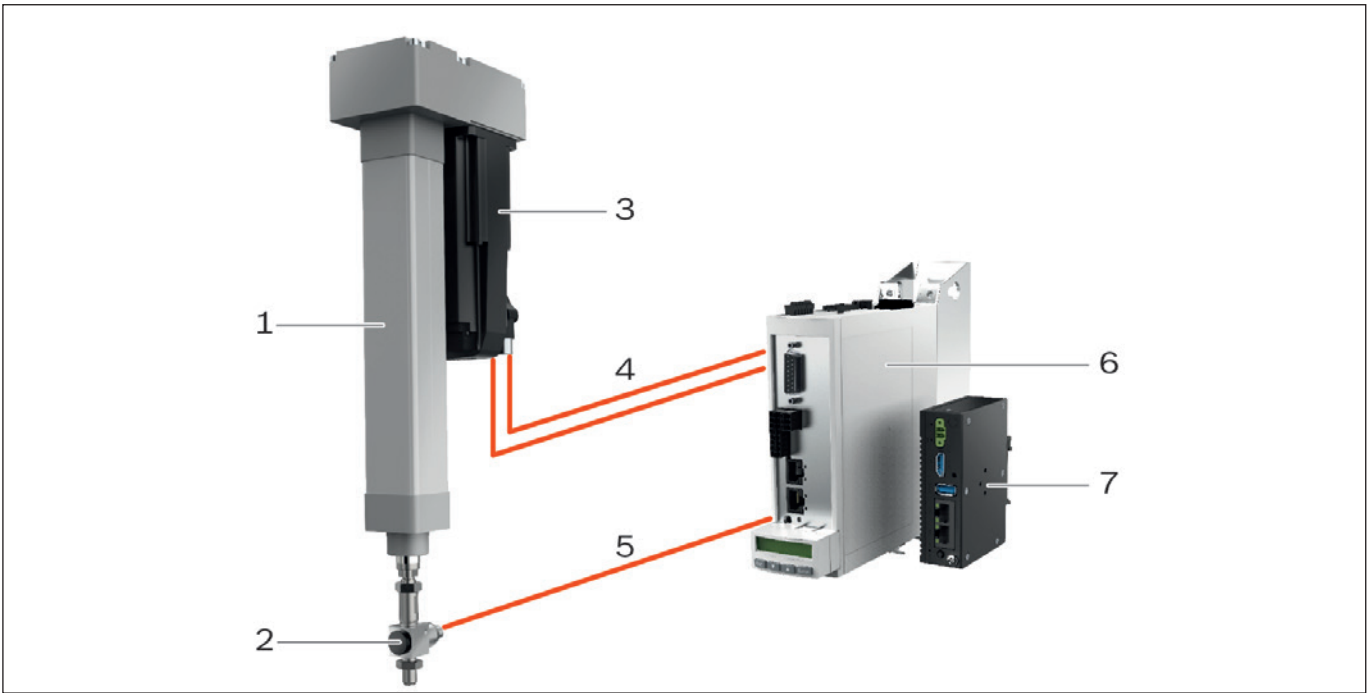

Fig. 1: Components

- 1 Electromechanical cylinder EMC with freely configurable travel ranges. Parallel or axial motor attachment
- 2 Force sensor: DMS technology for cost-effective and robust force measurement
- 3 MS2N Servo Motor: Latest generation of motors with absolute encoder and brake
- 4 Motor cable
- 5 Sensor cable
- 6 IndraDrive HCS01 Drive Controller with integrated PLC IndraMotion MLD and STO safety function or Safe Motion
- 7 Industrial PC PR21 with integrated web server and Smart Function Kit HMI software

4.2 Product identification

The product nameplate bears the following information:

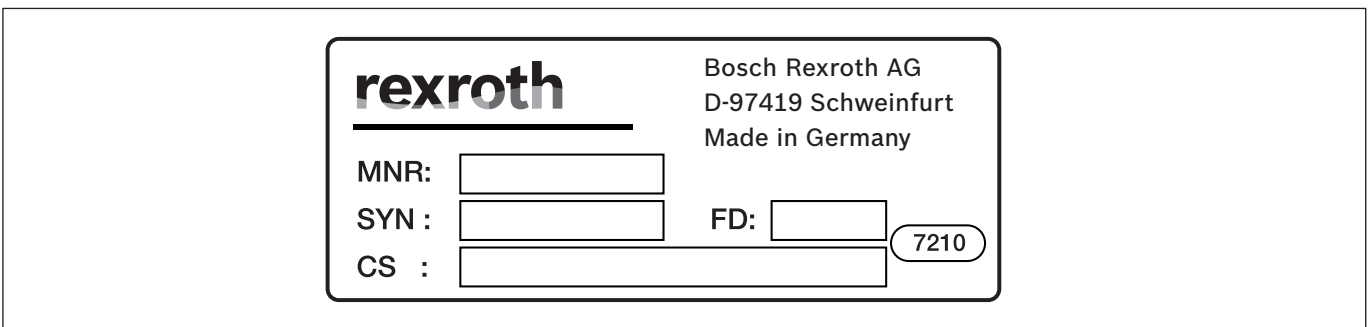

Fig. 2: Name plate

Table 5: Information on name plate

Name plate information	Meaning
MNR	Material number
TYP	Type designation and size
CS	Customer order number
FD	Date of manufacture
7210	Manufacturing location

When ordering spare parts, please specify all the data on the nameplate.

5 Transport and storage

Take note of the environmental conditions ➡ 12 and product catalog. For special environmental conditions, please consult us.

5.1 Transporting the Smart Function Kit

⚠ WARNING

Risk of product falling due to inadequate load handling equipment!

Death or severe injury.

- ▶ Use only inspected and suitable load handling equipment.
- ▶ Fasten load handling equipment only to the frame or at the designated points.
- ▶ Do not stand under suspended loads.
- ▶ Before hoisting, take note of the weight.

NOTICE

Risk of damage to motor attachment due to motor vibrations/motor breaking off!

Damage to the product.

- ▶ When transporting the product with mounted motor, always provide support for the motor.

5.2 Storing the Smart Function Kit

NOTICE

Risk of damage to the drive components due to improper storage!

Damage to the product.

- ▶ Store the drive components in their original packaging, in a dry place, dust-free, vibration-free and protected from light or direct sunlight.

Risk of damage due to improper storage!

Potential corrosion of product parts.

- ▶ Store the product only in dry, covered areas.
- ▶ Protect the product from humidity and corrosive agents.

Elastomer seals accelerate aging.

- ▶ Protect the product from heat and light (UV radiation).

6 Assembly

For dimensions and material numbers of the individual components ➔ Product catalog.

⚠ WARNING

Risk of product falling if installed vertically or suspended due to lack of protection against falling loads!

Death or severe injury.

- ▶ Secure the product against falling.
 - ▶ Do not stand under the product in the hazard zone.
- ▶ Before hoisting the product, note the weight ➔ Product catalog.

NOTICE

Excessive or insufficient tightening torque

Product will be destroyed.

- ▶ Always observe the tightening torque ➔ 12.1

6.1 Installation conditions

- ▶ Note the operating conditions ➔ 12 and product catalogs. For special operating conditions, please contact us.

NOTICE

Risk of damage due to improper loads!

Damage to the product.

- ▶ Do not place any protruding loads on the product (for maximum values, see product catalog).
- ▶ Do not turn the piston rod.
- ▶ Do not use the housing for attaching other machine elements to absorb forces.
- ▶ Attach only standard Rexroth elements to the housing.

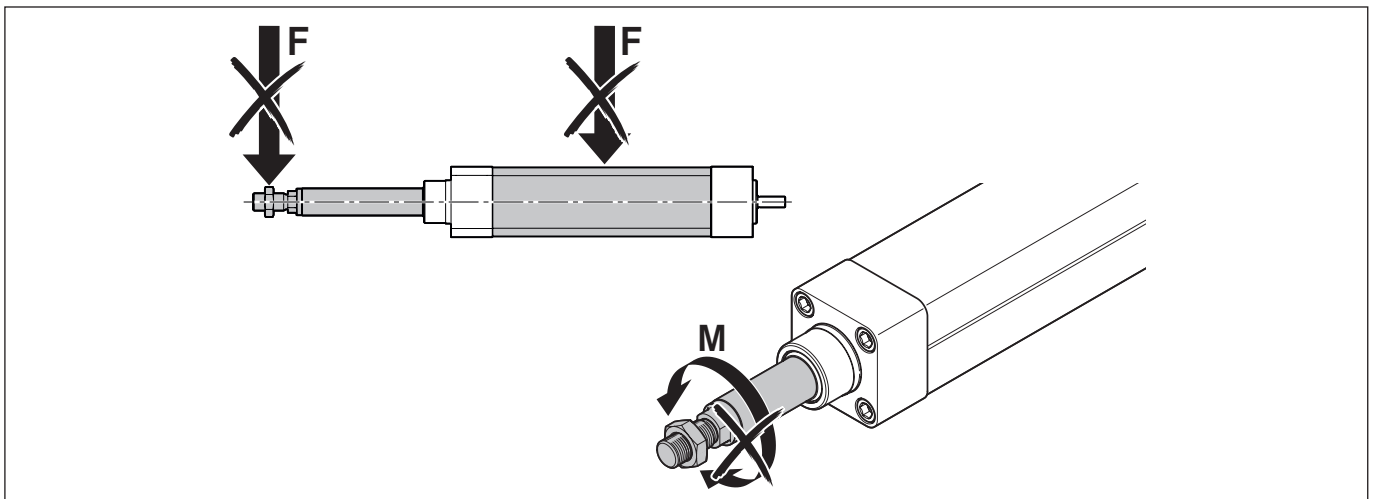

Fig. 3: Non-permissible loads

6.2 Installation position

The EMC can be mounted in any position.

⚠ WARNING

Risk of piston rod crashing down in vertical or slanting installations as the unit is not self-locking or risk of damage to mechanics inside the electromechanical cylinder or breakage of toothed belt in case of motor mounting using a belt side drive!

Death or severe injury.

- ▶ In vertical or slanting installations, secure the piston rod against falling.
- ▶ Do not stand under the product in the hazard zone.



Fig. 4: Dropping of the piston rod

6.3 Required accessories

- ▶ Required mounting accessories ➔ Product catalog, chapter "Fastening elements".

6.4 Fastening options

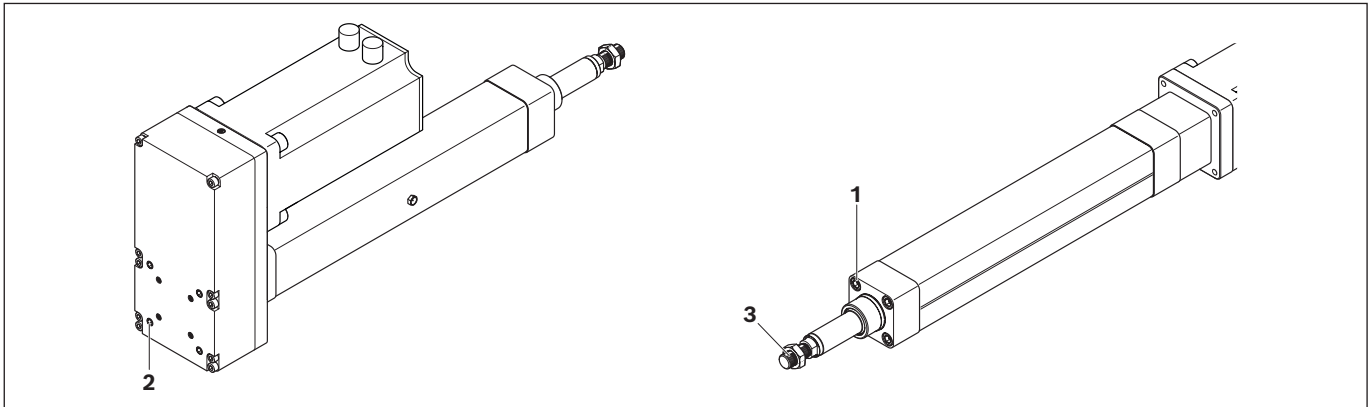

Fig. 5: Fastening options

- 1 By the cover
- 2 By the belt side drive
- 3 By the piston rod end

6.4.1 Permissible forces for fastening elements

⚠ CAUTION

Some fastening elements are not approved up to the "Maximum permissible axial force of EMC F_{MAXEMC} ".

Risk of injury.

- ▶ Observe the permissible maximum forces F_{max} for fastening elements in the chapter "Fastening elements" in the product catalog.

6.5 Mounting the force sensor

NOTICE

If the SFK is ordered without a force sensor a suitable third-party sensor must be installed.

Damage to the mechanical system inside the cylinder due to the initiation of torques to the product.

Damage to the product.

- ▶ Do not transfer any torque to the piston rod.
- ▶ Counterhold by means of a wrench flat.

Damage to the sensor due to transverse forces and torsional moments!

Damage to the product.

- ▶ Do not transfer any transverse forces or torque to the sensor.
- ▶ Counterhold by means of a wrench flat.

Measuring error due to lock nut attached to the sensor body!

Measurement error when the lock nut of the workpiece side touches the force sensor.

- ▶ Lock the lock nut at a distance from the sensor body. ➔ ☒ Fig. 6; image 3

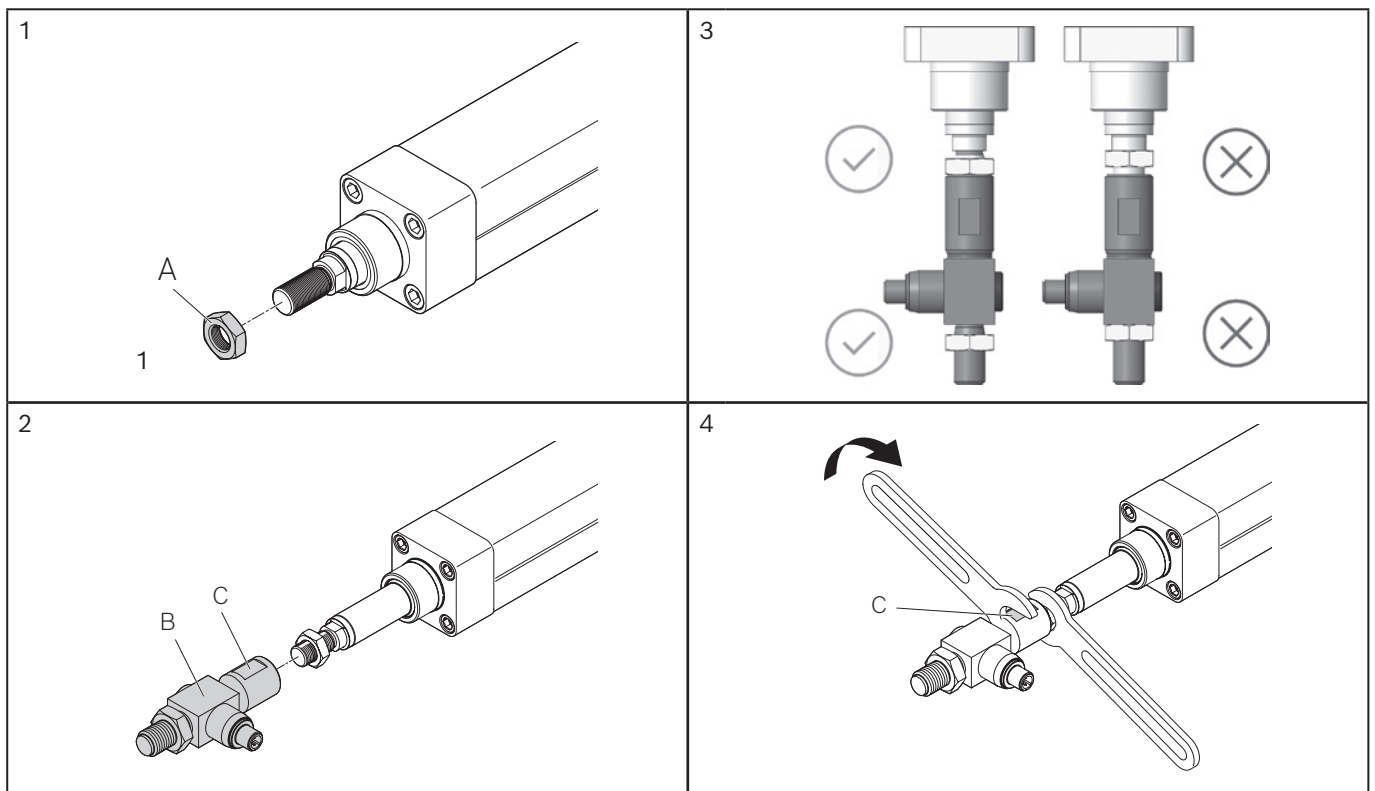

Fig. 6: Assembly, force sensor

1. Screw the lock nut (A) to the threaded bolt of the EMC.
2. Screw the force sensor (B) onto the threaded bolt. Recommendation: use half of the thread length of the threaded bolt.
3. Secure the position of the force sensor with the lock nut and observe the position of the lock nut (do not screw it in all the way).
4. Tighten the force sensor hand-tight with tightening torque $M_{A,h}$. While doing so, counterhold the sensor at the wrench flat (C) to avoid torsional moments on the sensor.

EMC / SPK	40 / 002	50 / 004	63 / 007	80 / 012	100 / 019	100XC / 030	130 / 045	160 / 070
Thread	M12x1,25	M16x1,5	M16x1,5	M20x1,5	M20x1,5	M36x2	M33x2	M42x2
$M_{A,h}$ (Nm)	15	35	35	60	60	350	285	415

5. Tare the system immediately after assembly

6.6 Mounting the EMC

NOTICE

Function failure of product due to incorrect mounting (distortive stress)!

Damage to the product.

- ▶ Install the EMC so it is free of distortive stresses!

1. Bring the EMC into position.
2. Tighten the fastening screws evenly. Take care not to exceed the maximum permitted tightening torques $M_A \Rightarrow$ 12.1 "Table 27: Tightening torques" on page 36.

6.7 Connecting the electrical power supply to the EMC

⚠ WARNING

Risk of electric shock due to contact with live parts!

Death or severe injury.

- ▶ Before working on the electrical equipment, switch off the power supply and secure it against being switched on again.
 - ▶ Follow the safety instructions given in the documentation for the controller used.
-
- ▶ Observe the safety regulations for working with high-voltage equipment!
 - ▶ Consult the documentation for the motor/controller used.
 - ▶ For the electrical connection, observe the notes from "7 Installation" on page 14.
 - ▶ For motors with a two-cable connection: lay the motor cable (1) at a distance from the encoder cable (2)!

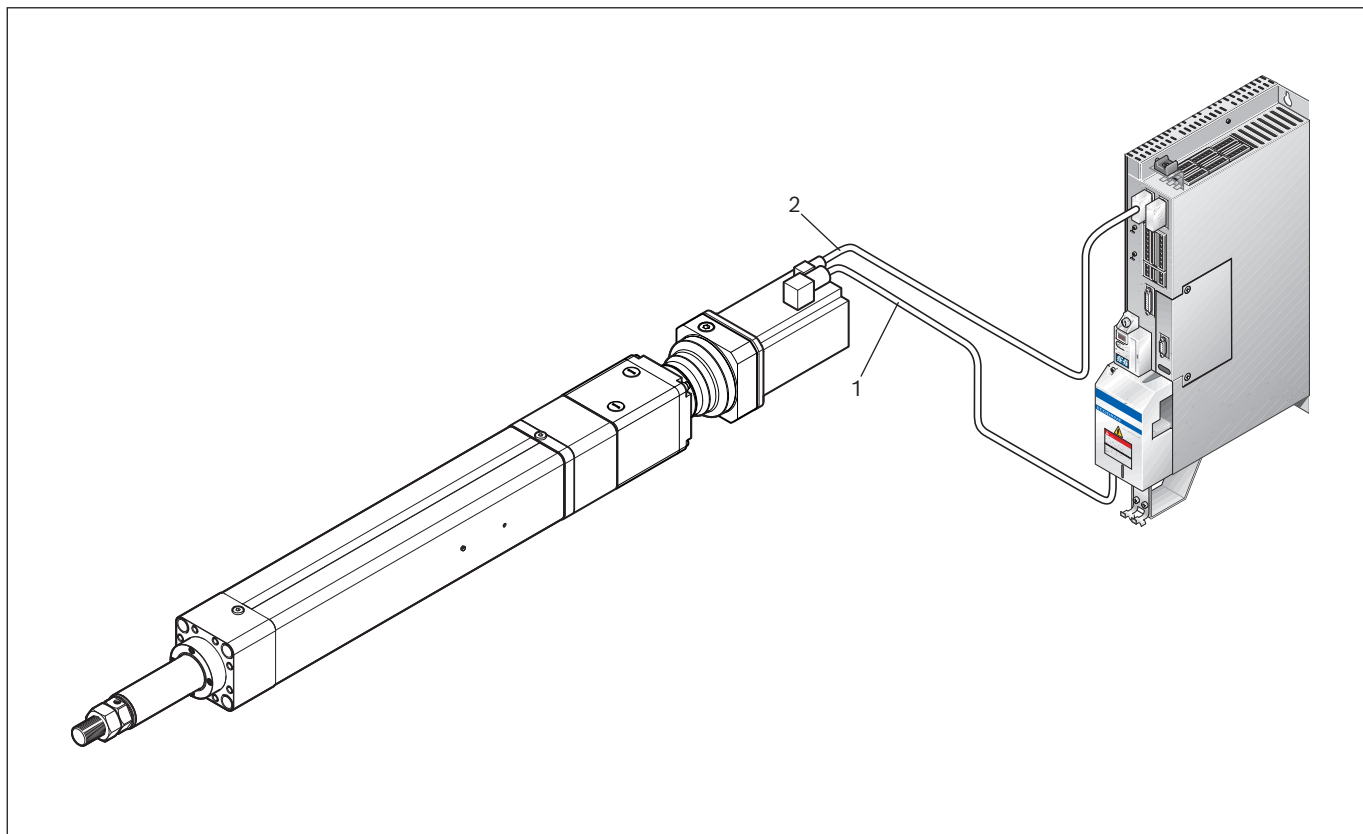

Fig. 7: Connecting the motor to the drive controller HCS01

6.8 Connecting the fan unit

The motors MS2N07-D0BHA and MS2N10-D0BHA are supplied with an integrated fan. As a result, the continuous power is significantly increased with the same size.

- To connect the fan unit, use a connection cable 3 x 0.75 mm²

Table 6: Fan unit connector for MS2Nxx-xxxxA (UN 230 V) / MS2NxxxxxxB (UN 115 V)

Assignment		Connection
1	L1 230 V	Phase for 230 V
2	N	Neutral conductor
3	L1 115 V	Phase for 115 V
⊕	PE	Protective conductor

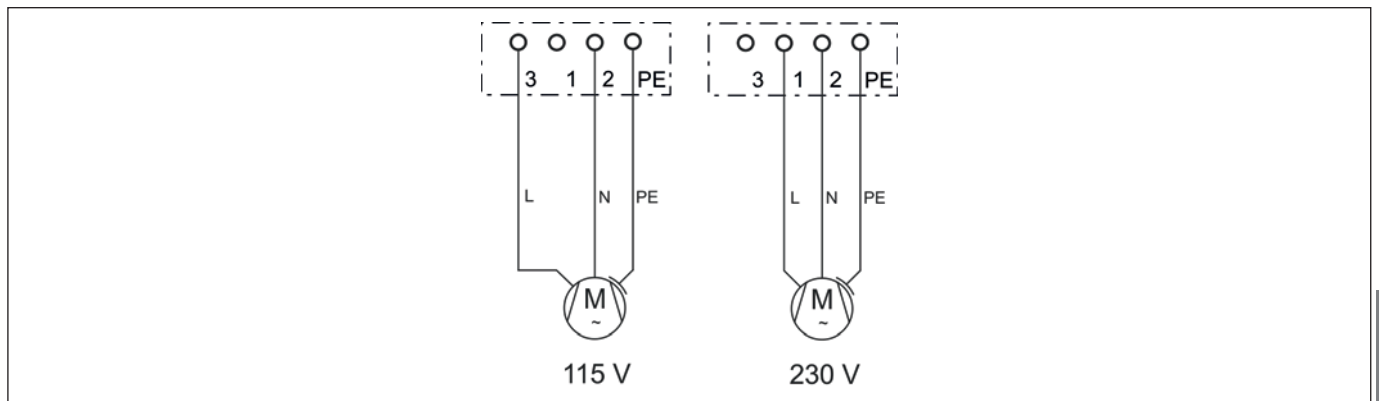
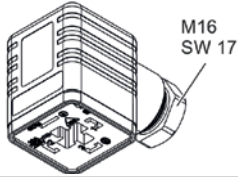

Fig. 8: MS2N connection fan 115 / 230 V

7 Installation

⚠ WARNING

Risks related to moving parts!

Moderate injury, including severe flesh wounds, puncture wounds and severe bruising.

- ▶ Never reach into moving parts.

Unexpected movement of the product!

Risk of injury due to impact or bruising.

- ▶ Before working on the electrical equipment, switch off the power supply and secure it against being switched on again.

Risk of electrical shocks through touching live parts!

Death or serious injury.

- ▶ Before working on the electrical equipment, switch off the power supply and secure it against being switched on again.
- ▶ Allow drive components to discharge before accessing them.
- ▶ Always operate the drive components with a permanently installed protective conductor.

7.1 General installation instructions

- ▶ Observe the required minimum distances during mounting (see technical data or dimension sheets).
- ▶ Rear mounting (rear side of the device is directly on the mounting surface in the control cabinet) is the standard and should be applied.
- ▶ Lay all lines in loops. Use strain reliefs for all lines.
- ▶ Do not lay signal-carrying cables parallel to motor cables or other strong sources of interference over long distances as the signal transfer may otherwise be interfered. If possible, keep great distance to interference sources.

7.2 Installation of the HCS01 drive controller

7.2.1 IndraDrive HCS01 device overview

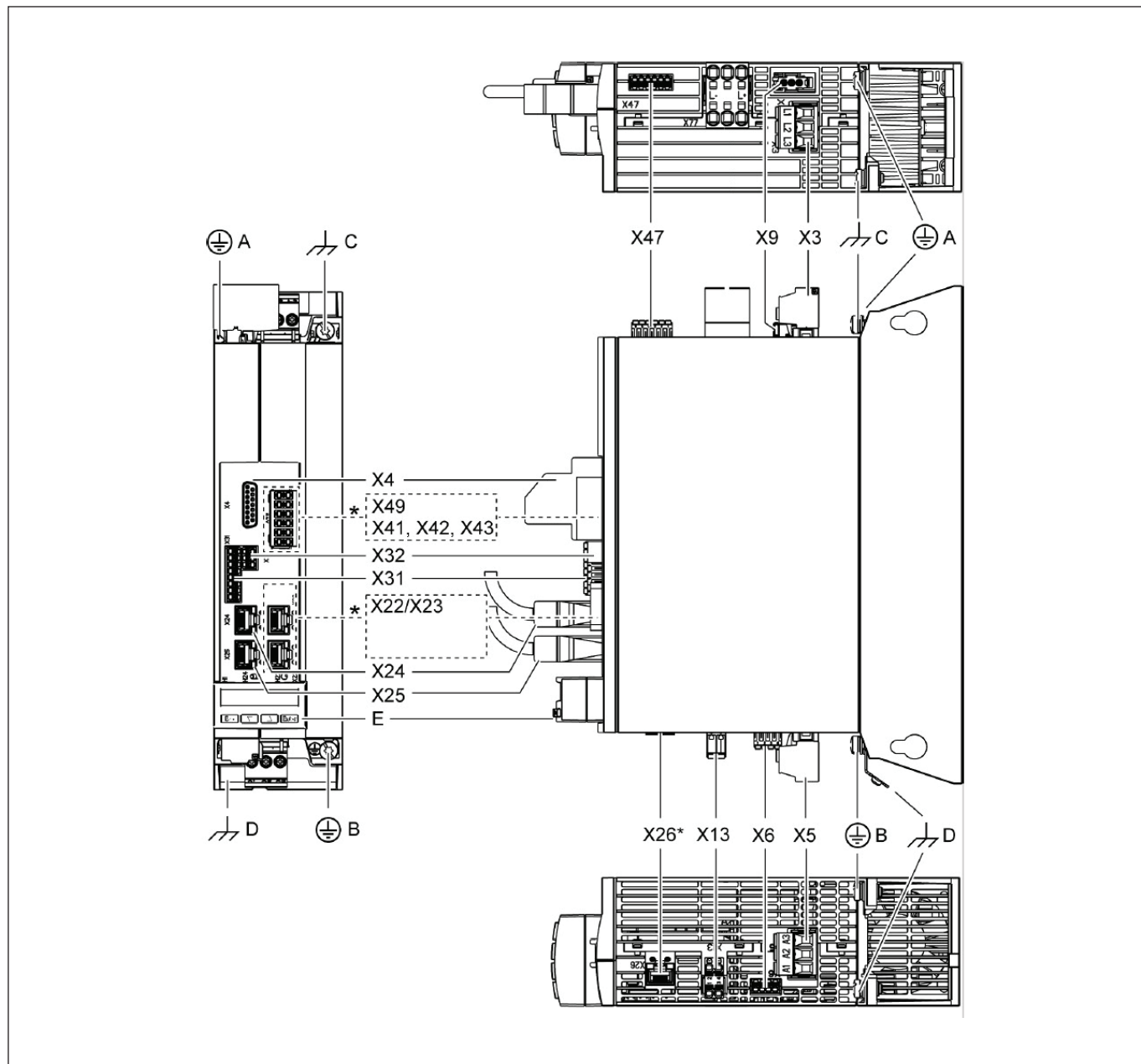

Fig. 9: IndraDrive HCS01

A	Protective conductor connection, mains	X22/X23	Multi-Ethernet communication (option ET)
B	Protective conductor connection, motor	X24/X25	Sercos III master
C	Shield connection, control lines	X26	Engineering interface (Only available on ADVANCED devices A-CC)
D	Shield connection, motor cable	X31	Digital inputs, digital output
E	Operating panel	X32	Analog input
X3	Mains connection	X41, X42, X43	Safety technology (option S4, S5: Safe Motion)
X4	Motor encoder	X47	Bb relay contact, module bus (module bus only on devices HCS01.1E-W00xx-x-03)
X5	Motor connection	X49	Safety technology (option L3: Safe Torque Off; Option L4: Safe Torque Off, Safe Brake Control)
X6	Motor temperature monitoring, motor holding brake		
X9	integrated/external brake resistor		
X13	24 V supply (control voltage)		

7.2.2 Protective conductor connection

- ▶ Connect the protective conductor of the mains or motor cable with the device housing via the M5 thread \oplus (identification; tightening torque: 5 Nm). The required screws M5x12 are part of the scope of delivery.
- ▶ The connection of the protective conductor is done immediately on the device, not via the connection point X3 (see description of the wire connection).

7.2.3 X3, Mains connection

- ▶ Measure the required cross section of the connection cables according to the determined phase current ILN and the mains fuse.
- ▶ For single-phase mains connection (phase conductor and neutral conductor): Connection via X3 can be made via L1, L2 or L3 as required.
- ▶ Ensure that the connection terminals of the device in the control cabinet are strain-relieved.
- ▶ Observe the notes in the project planning description R911322209 for the use of mains filters and other measures for minimizing interference.

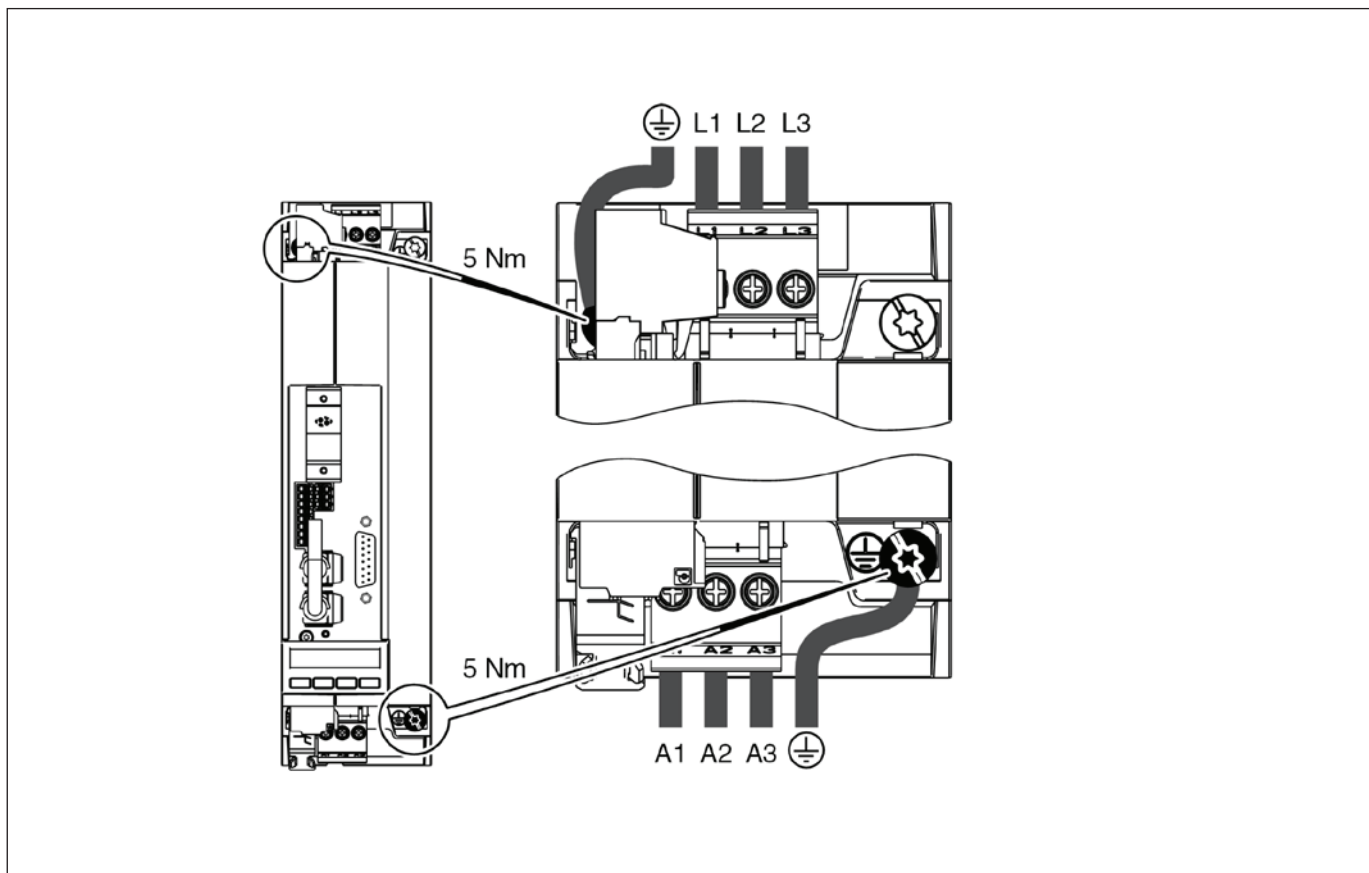

Fig. 10: X3, Mains connection

L1, L2, L3 Mains connection

A1, A2, A3 Motor connection

7.2.4 X4, Motor encoder connection

► For connection between the drive control unit and the motor, preferably use the motor encoder cable supplied.

Table 7: X4

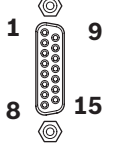
	X4	Motor encoder connection
---	-----------	--------------------------

7.2.5 X5, Motor connection

► For an optimum shield connection of the motor power cable, use the supplied accessories HAS09.

Table 8: X5

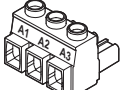
	A1	for line terminal U1 at the motor
	A2	for line terminal V1 at the motor
	A3	for line terminal W1 at the motor

7.2.6 X6, Motor temperature monitoring and motor holding brake

- Via an integrated switching device (BR), the power unit switches the voltage of the external 24 V supply to the output for controlling the motor holding brake.

Table 9: X6

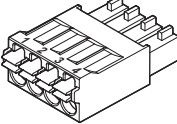
	1	MotTemp+	Motor temperature monitoring input
	2	MotTemp-	
	3	+24 VBr	Output for controlling the motor holding brake
	4	0 VBr	

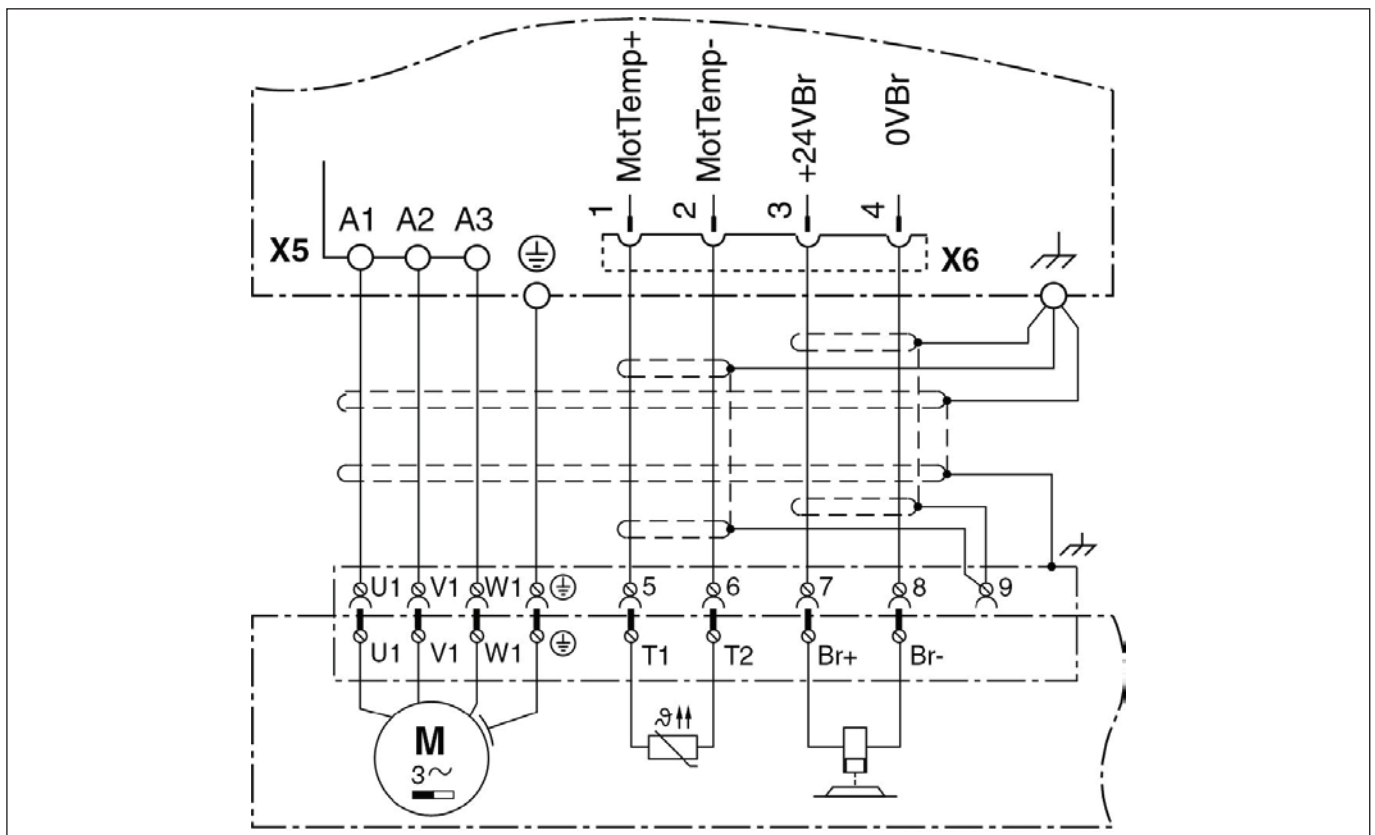

Fig. 11: Motor temperature monitoring

7.2.7 X9, Integrated brake resistor

- X9 is used to connect the HRL integrated brake resistor.
- ▶ Only operate the device with the attached connection plugs (even if there are no lines connected to the connection plugs).

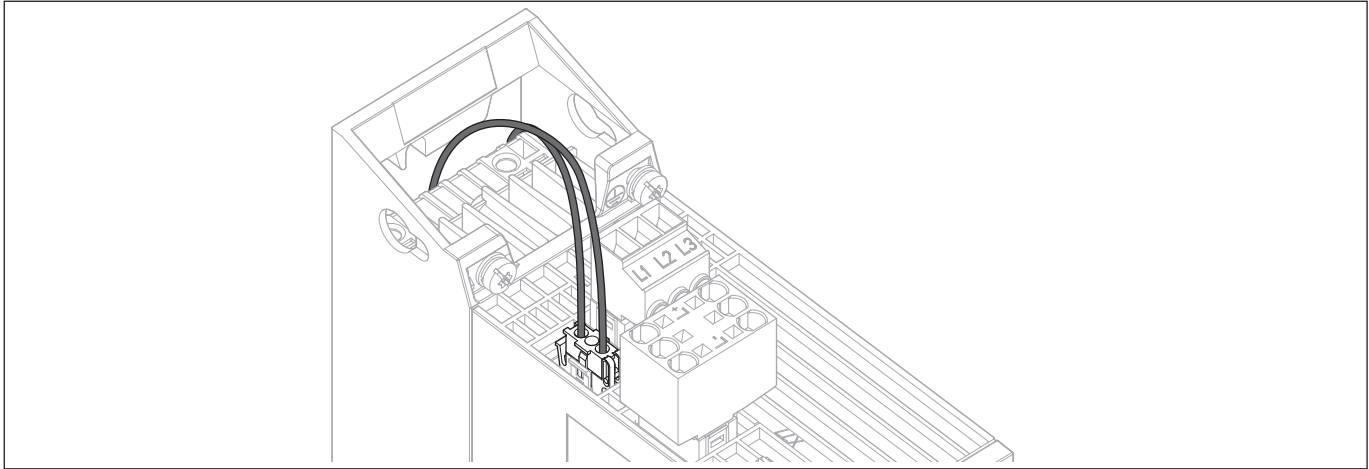

Fig. 12: Integrated brake resistor

7.2.8 X13, 24 V supply (control voltage)

Via the connection point X13, the 24 V supply is externally created for

- the controller and power unit of the drive control unit
- the brake control according to X6
- the digital inputs and the digital output according to X31 / X32

Table 10: X13

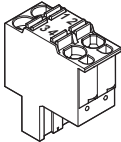
	1	0 V	Reference potential for the power supply
	2	0 V	
	3	+24 V	Voltage supply
	4	+24 V	

7.2.9 X31, Digital inputs / outputs

- The mass potential of all inputs refers to the reference potential of the control voltage supply at connection X13.
- Port 8 can be used as a digital output.
- The output current of the digital output (connection 8) is max. 500 mA.
- The configuration of the digital inputs / outputs is done in the Smart Function Kit software.
- Port 3 is pre-occupied as an emergency stop and can be deactivated in the software after commissioning, if required. Alternatively, the "Stop and Torque Off" function can be activated ➔ 7.2.12.

Table 11: Digital input X31

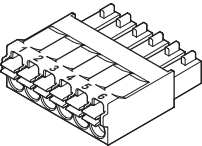
	1	I_1	Digital input
	2	I_2	
	3	I_3	Emergency stop pre-allocation
	4	I_4	Digital input
	5	I_5	
	6	I_6	
	7	I_7	
	8	I/O_8	Digital output

7.2.10 X32, Analog input



The E-stop function serves to stop the drive via a digital input of the drive control device. The polarity of the input cannot be selected. It is always zero active; i.e. 0 V at the digital input causes the E-stop to be triggered. ➔ 7.2.12.

- For the connection "Analog input" ➔ "7.5 Installation of the force sensor" on page 29

Table 12: X32

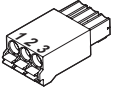
	Permissible input voltage	V	-30	+30
	Working range input voltage	V	0	+10
	Bandwidth	kHz	1.3	
	Resolution	Bit	12	
	Cable		Only use shielded cables for cable lengths > 30 m.	

7.2.11 X47, Relay contact ready for operation (Bb)

- ▶ Wire the relay contact Bb (connection 1 and 2) in the control circuit of the mains connection. If the contact opens, the mains contactor must interrupt the power supply.

Table 13: X47

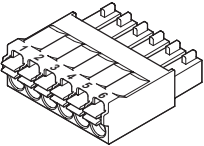
	1	Rel1	Bb relay contact
	2	Rel2	Bb relay contact

7.2.12 X49, Safety technology L3 / Safe Torque Off

Table 14: X49

	SI_Ch2	1	SI_Ch2	Input selection channel 2
	0V	2	0 V	GND reference of the inputs and outputs
	SI_Ch1	3	SI_Ch1	Input selection channel 1
	+24V	4	+24 V	Voltage supply, dynamization outputs
	Dyn_Ch2	5	Dyn_Ch2	Dynamization output channel 2
	Dyn_Ch1	6	Dyn_Ch1	Dynamization output channel 1

By using the E-Stop function of the drive, the STO function can be extended to the "Safe Stop 1 (EMERGENCY STOP)" function. For this purpose, the selecting safety unit (e.g. time relay) must first stop the drive via the E-Stop function (standstill of the motor is initiated). After a fixed time delay has elapsed, the STO must be selected.

The selection must always be made after the set time, regardless of the state of the axis.

Instead of the "E-Stop" function, the "Stop and Torque Off" function can be assigned to pin X31.3. After this function is selected, the motor is stopped and torque turned off. Subsequently, the STO can be selected and deselected without error message of the drive. Instead of an error message, a warning is displayed. In the web interface, the activated emergency off is displayed with a "Safety warning" status instead of "Error". After a rising signal edge at input IX31.3 (e.g. emergency off is pulled), the drive is automatically switched back to "Drive stop" (AH) mode. The warning disappears and the system status is changed to "Ready". In this operating mode, the axis can be moved again.

➔  Fig. 13

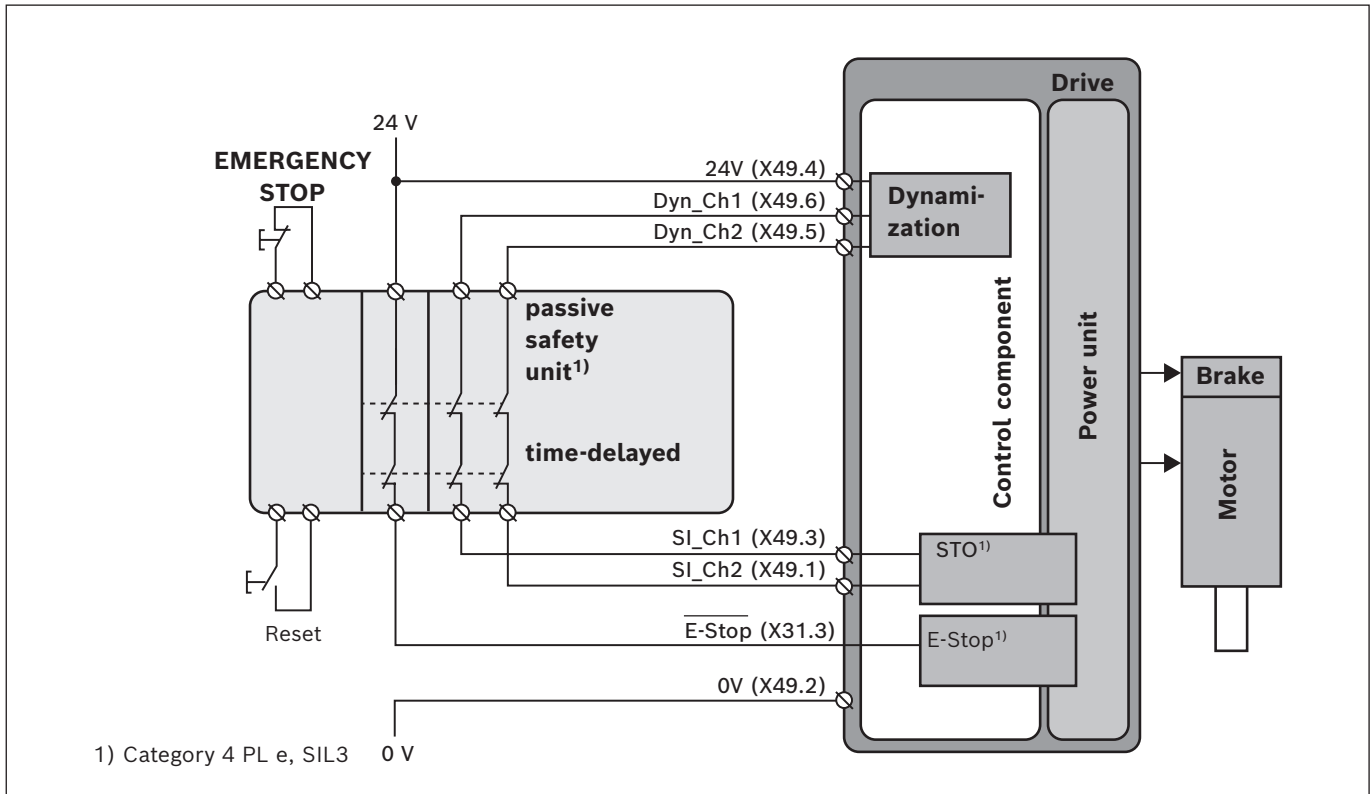

Fig. 13: Application example: Safe stop 1 function with dual-channel wiring and passive safety unit

7.2.13 X41, safety technology Safe Motion S4

Table 15: X41

	1.1	SI_Out_Ch2	Secure output channel 2
	1.2	0 V	Voltage supply to the inputs/outputs (U_{ext})
	1.3	SI_Out_Ch1	Secure output channel 1
	2.1	SI_In_Ch2	Input 2
	2.2	24 V	Voltage supply to the inputs/outputs (U_{ext})
	2.3	SI_In_Ch1	Input 1

7.2.14 X42, X43 safety technology S4 / Safe Motion

"The safety functions of the Safe Motion can be selected via the safe inputs of the safety zone module "HSZ01". For this purpose, the safety zone module "HSZ01" must be connected to the axis of the safety zone via the zone bus (X42, X43). The safety zone module "HSZ01" provides 2 x 8 digital inputs for dual-channel common selection or 16 inputs for single-channel selection of the safety zone (see chapter 7.5 "Installation of the HSZ01 safety zone module").

Table 16: X42/X43

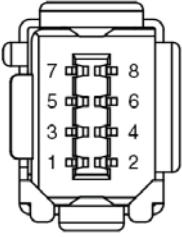
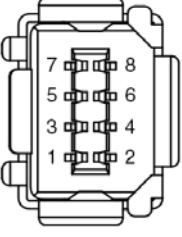
 <p>X42:</p>	 <p>X43:</p>	<p>X42 X43</p>	<p>Connection points for the connection of the safety zone module HSZ01¹⁾ and the safety zone participants: X42: Input X43: Output</p>
---	---	--------------------	---

¹⁾ For further information, see the project planning description "IndraDrive add-on components and accessories" (R911306139).

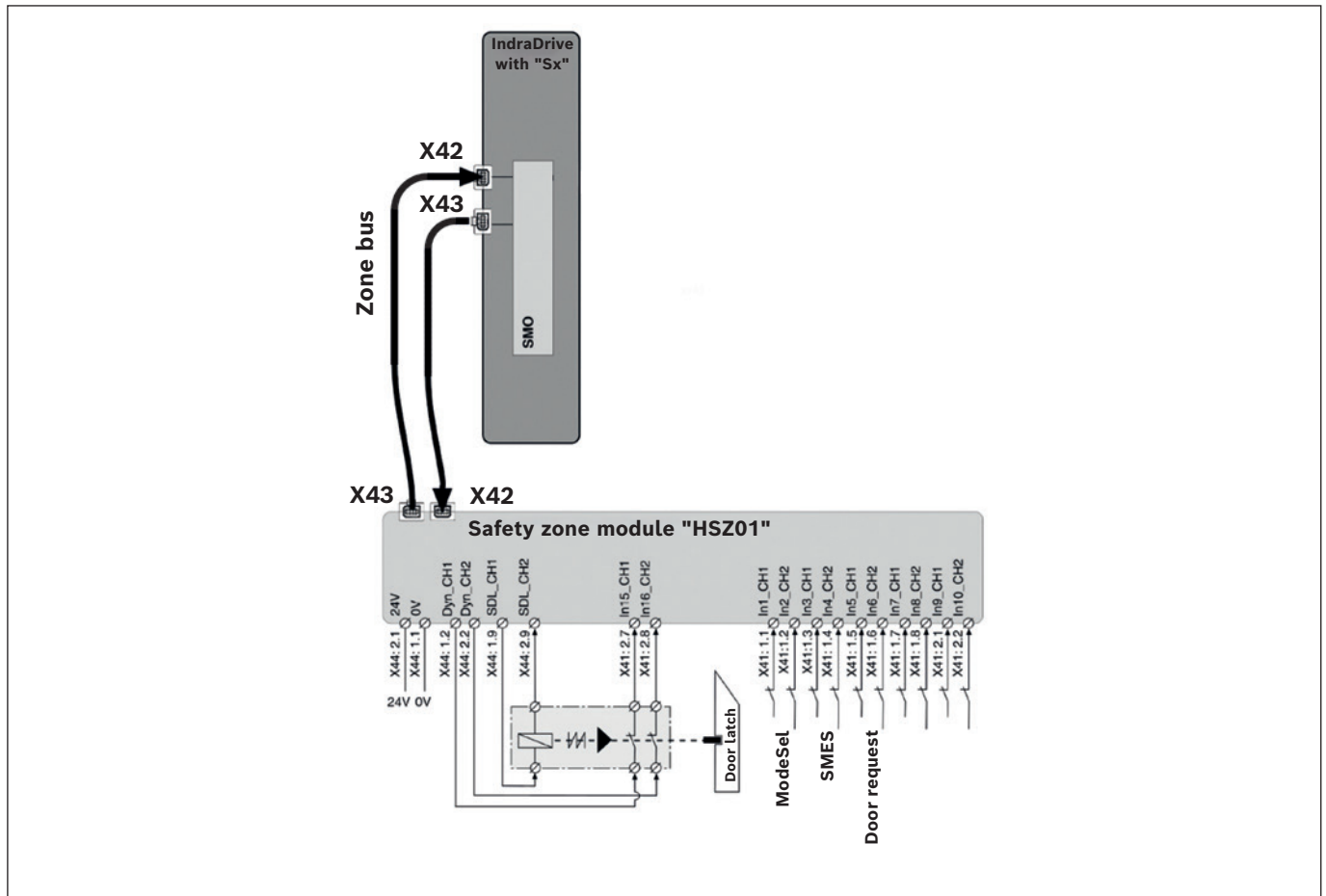

Fig. 14: Example of zoning with safety door lock

7.3 Installation of the HSZ01 safety zone module with S4 safety option

For further information see project planning description "IndraDrive add-on components and accessories" (R911306139 chapter 18).

Table 17: HSZ01

HSZ01	The HSZ01 safety zone module is part of the Rexroth IndraDrive product family and serves the following safety functions: - Safety Zone Acknowledge (SZA) - Safety Zone Error (SZE) - Safety Zone Input (SZI) - Safe Door Locking (SDL)
-------	--

7.3.1 Device overview HSZ01 safety zone module

Features:

- 2 × 8 digital inputs for 2-channel common selection of the safety functions at the safety zone participants or 16 inputs for 1-channel selection.
- 2 × 1 digital dynamized output (1 output pair) for safety zone acknowledgment when all safety zone participants indicate safety.
- 2 × 1 digital dynamized output (1 output pair) safety zone error if at least one safety zone participant indicates an error.
- 2 × 1 digital dynamized output (1 output pair) for monitoring the wiring.
- 2 × 1 digital output (1 output pair) for controlling the secure safety door lock.
- Galvanic separation exists between the inputs and outputs of the safety zone module and the other participants of a safety zone.

Table 18: Connection points

	XS1	Shield connection
	X41	Digital inputs
	X42	Communication, input
	X43	Communication, output
	X44	Digital outputs Control voltage supply connection
		Protective conductor
	H2 (LED)	Status display (two-color LED)

7.3.2 X41 digital inputs

Table 19: X41, digital inputs

	X41	Safe Motion
---	-----	-------------

Connection	Signal name	Function	Dynamization	Input pair
1.1	In_1	Input 1	DYN_Ch1	1
1.2	In_2	Input 2	DYN_Ch2	
1.3	In_3	Input 3	DYN_Ch1	2
1.4	In_4	Input 4	DYN_Ch2	
1.5	In_5	Input 5	DYN_Ch1	3
1.6	In_6	Input 6	DYN_Ch2	
1.7	In_7	Input 7	DYN_Ch1	4
1.8	In_8	Input 8	DYN_Ch2	
2.1	In_9	Input 9	DYN_Ch1	5
2.2	In_10	Input 10	DYN_Ch2	
2.3	In_11	Input 11	DYN_Ch1	6
2.4	In_12	Input 12	DYN_Ch2	
2.5	In_13	Input 13	DYN_Ch1	7
2.6	In_14	Input 14	DYN_Ch2	
2.7	In_15	Input 15	DYN_Ch1	8
2.8	In_16	Input 16	DYN_Ch2	

7.3.3 X44, digital outputs

Table 20: X44, digital outputs

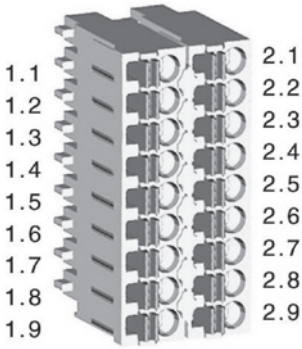
	X44	Safe Motion
---	-----	-------------

Function	Connection	Signal name	Technical data
Voltage supply	2.1	24V	Voltage: DC 19.2 ... 30 V ¹⁾
Voltage supply	1.1	0 V	Reference potential of the voltage supply
Output zone error channel 1	1.7	SZE_Ch1	<ul style="list-style-type: none"> High on both outputs: All participants are without errors Low on both outputs: At least one participant has an error
Output zone error channel 2	2.7	SZE_Ch2	
Output zone security channel 1	1.8	SZA_Ch1	<ul style="list-style-type: none"> High on both outputs: All participants are safe Low on both outputs: At least one participant is not safe
Output zone security channel 2	2.8	SZA_Ch2	
Output secure safety door lock channel 1	1.9	SDL_Ch1	Output pair for the control of a door lock. If the door latch is correctly activated, SDL_Ch1 = High and SDL_Ch2 = Low.
Output secure safety door lock channel 2	2.9	SDL_Ch2	
Dynamization output channel 1	1.2	DYN_Ch1	An output pair for dynamizing the external wiring. For simpler wiring, the connection of the output pair is present several times.
Dynamization output channel 2	2.2	DYN_Ch2	
Dynamization output channel 1	1.3	DYN_Ch1	
Dynamization output channel 2	2.3	DYN_Ch2	
Dynamization output channel 1	1.4	DYN_Ch1	
Dynamization output channel 2	2.4	DYN_Ch2	
Dynamization output channel 1	1.5	DYN_Ch1	
Dynamization output channel 2	2.5	DYN_Ch2	
Dynamization output channel 1	1.6	DYN_Ch1	
Dynamization output channel 2	2.6	DYN_Ch2	

¹⁾ If the safety door lock requires a tighter tolerance of the voltage, the power supply used must adhere to the tolerance of the safety door lock.

7.3.4 X42 and X43, safety technology Safe Motion (communication)



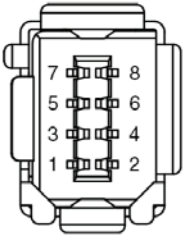
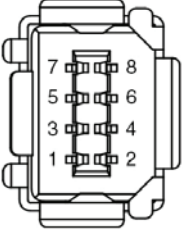

Table 21: X42 and X43 digital outputs

 <p>X42:</p>	 <p>X43:</p>	X42	Connection points for the connection of the HSZ01 safety zone module ¹⁾ and the safety zone participants:
		X43	X42: Input X43: Output

¹⁾ For further information, see the project planning description "IndraDrive add-on components and accessories" (R911306139).

7.3.5 LED H2

Table 22: LED H2

LED	Color	Description
	 Off	<ul style="list-style-type: none"> Supply voltage missing Device defective
H2	 Illuminated green	Device works without errors
	 Red, flashing	Error present: See diagnostic display (e.g. F3152) on the drive control unit Troubleshooting: See the "Diagnostics" firmware documentation
	 Illuminated red	<ul style="list-style-type: none"> Hardware error Firmware error Communication errors; diagnostic display: F7033

7.3.7 Shield connection

- ▶ Special sheets are used for the shield connection for cables that are connected to the device. The sheets are part of the scope of delivery and are screwed to the device.
- ▶ The shield connection is not used for relieving the strain on the cables. Mount a separate strain relief near the drive control unit.

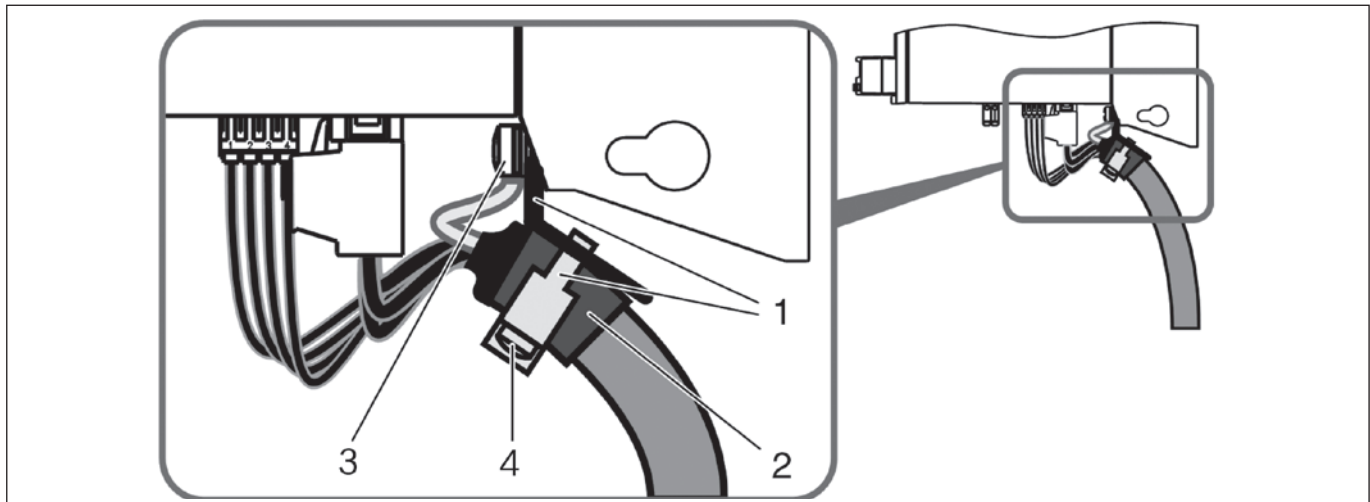

Fig. 16: Shield connection

- 1 Cover plates
- 2 Shield of the motor cable
- 3 Screw (M5x12 or M5x16); tightening torque 5 Nm
- 4 Screw (M5x30); tightening torque 1 Nm

7.3.6 Operating panel and SD card

- The operating panel on HCS01 shows operating states, command and error diagnoses and pending warnings.
- The system only works with the attached operating panel.
- Only use the supplied microSD card.
- Only insert the microSD card laterally into the operating panel when the system is switched off.
- The system only works with the inserted microSD card.



Fig. 15: Operating panel

⚠ CAUTION

Changes to the contents of the microSD card.

Restriction of the system function.

- ▶ Do not change the contents and structure of the microSD card manually.

7.4 Installation of the industrial PC PR21

7.4.1 Industrial PC PR21 device overview

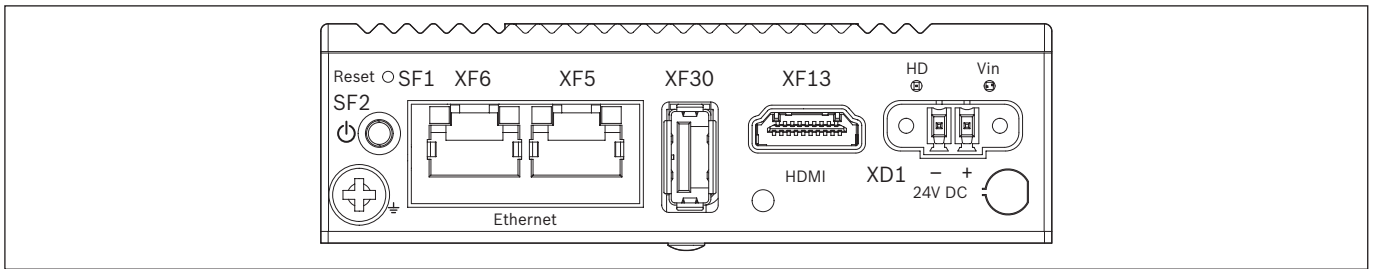

Fig. 17: Connection

XD1	Voltage supply
SL1	Protective conductor connection
XF5/XF6	Ethernet port
XF13	HDMI monitor connection (no HMI display)
XF30	USB 3.0 port

7.4.2 SL1, Wire connection

- ▶ Connect a protective conductor to connection SL1 in the industrial PC PR21. Use a cable lug on the protective conductor.

7.4.3 XD1, 24 V Power supply (control voltage)

- ▶ For connection of the 24 V power supply, use the supplied 24 V connection terminal.

Table 23: X13

	①	+24 V supply voltage
	②	0 V supply voltage

7.4.4 XF5, Connection between HCS01 drive controller and industrial PC PR21

- ▶ For the network connection between industrial PC PR21 and HCS01 drive controller, use a Cat5e network cable.
- ▶ The connection must be made directly.
- ▶ On PR21, use connection XF5.
- ▶ On HCS01, use connection X26.

7.5 Installation of the force sensor

7.5.1 Requirements on a customized force sensor

- Output signal: -10 V until +10 V
- Linear characteristic curve
- Force sensors with other characteristics, amplifiers or other devices for signal processing can be used provided they meet the two first mentioned requirements for the output signal.

7.5.2 Assembly of the force sensor

- ▶ Do not place the connection cable parallel to the power and control lines.
- ▶ Do not place the connection cable near transformers, motors and contactors.
- ▶ Use the supplied connection cable. If this is not possible, use a suitable low-capacity connection cable with shielding.
- ▶ **Connect the sensor cable shielding to ground.**

Table 24: Contact assignment force sensor / drive controller terminal X32

Force sensor	Standard Cable color	Assignment	Remark
GND (pin 3 socket)	BU	Pin 1 X32: GND_100 Pin 2 X32: I_a_1-	Bridge between pin 1 & 2; With no voltage applied, ~100 Ω must be measured to GND
Signal (pin 4 socket)	BK	Pin 3 X32: I_a_1+	-
VSS (pin 1 socket)	BN	Power supply, 24V	-
Shield		Power supply, 0V	only connected on one side!

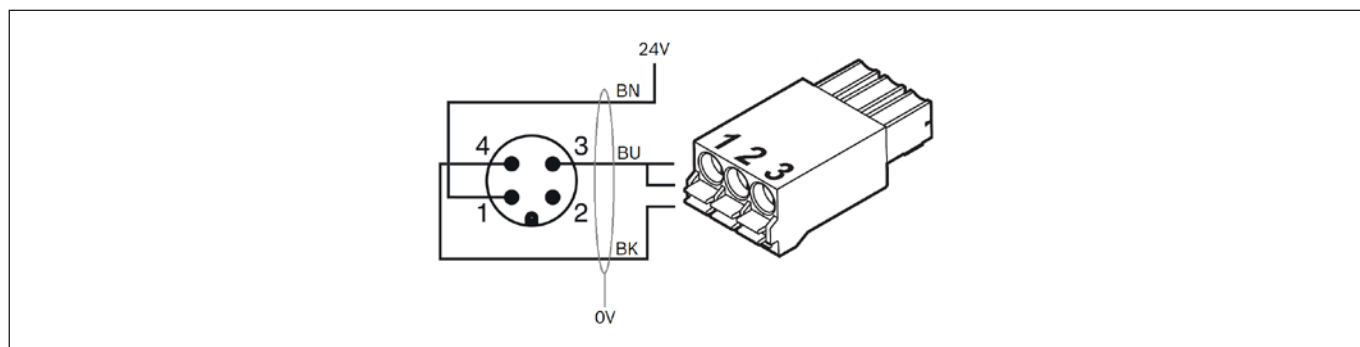

Fig. 18: Contact assignment force sensor (connector M12x1) / drive controller terminal X32

With the power off, check that there is ~100 Ω between pin 1 X32 and 0V (GND of the general power supply). If the resistance is ~0 Ω, there is a bridge between pin 1 X32 and 0V, which can affect the measurement signal. Ensure that the shield is only at 0V on one side. Connect pin 1 of the force sensor to the +24 V supply voltage.

7.6 Connection of the HMI terminal device

7.6.3 Requirements

The Smart Function Kit provides an intuitive, web-based HMI for commissioning, configuration and programming of the system.

The following requirements apply for the required customer-supplied HMI device (e.g. notebook, tablet):

- Web browser with HTML5 and Java Script support, e.g. Firefox version 52 or higher, Chrome version 74 or higher
- Screen resolution 1280 x 720 px or higher
- Recommended screen diagonal 10 inches (format 16:9) or higher

7.6.4 Direct connection to the Smart Function Kit

- For the network connection between industrial PC PR21 and the HMI device, use a Cat5e network cable.
- On PR21, use connection XF6.
- There must be a valid TCP / IP network connection between the HMI device and industrial PC PR21 (observe the network settings on the HMI device and adjust if necessary).

7.6.5 Setting the IP addresses

The system is configured with the following network settings by default:

- XF5 192.168.1.100
- X26 192.168.1.1
- XF6 192.168.0.1 (access to HMI)
- Subnet mask 255.255.255.0

The IP address for access to the HMI (interface XF6) can be adjusted on the interface of the Smart Function Kit. The address section 192.168.1.x cannot be used.

7.7 Connection of a higher-level controller

Via a field bus, the Smart Function Kit can be connected to a higher-level control system and then be controlled and monitored by it. In this configuration, the Smart Function Kit is the field bus slave and the higher-level control system is the field bus master.

The system supports the following field bus protocols:

- Sercos III
- EtherCAT (SoE)
- Ethernet/IP
- Profinet

The minimum supported cycle time (IO cycle update time) is 4 ms.

Use the Multi-Ethernet connection X22/X23 at the HCS01 for connection to a higher-level control system. For connection between the devices, use a Cat5e network cable.

The field bus IP address of the system can be adjusted via the display on HCS01. The address section 192.168.1.x cannot be used.

For further information on the implementation of the field bus ► "Smart Function Kit Software" instructions.

7.8 Connection to the IT infrastructure

CAUTION

Unauthorized access to the product via network connection.

From malfunctions and data loss to damage to the product.

- ▶ Protect the network against unauthorized access by using a firewall or a Virtual Private Network (VPN), for example.
- ▶ Prevent a connection with the Internet by suitable measures.

For integration into an IT system, the Smart Function Kit must be integrated in the corresponding network.

For this connection, use interface XF6 on PR21.

The IP address for interface XF6 can be adjusted on the interface of the Smart Function Kit.

The address section 192.168.1.x cannot be used.

The operation of systems and machines generally requires the implementation of a holistic IT security concept which is state-of-the-art.

Bosch Rexroth products are part of this holistic concept. The properties of the Bosch Rexroth products must be taken into account in a holistic IT security concept. The properties to be taken into account are documented in the IT security guidelines (R911342561).

8 Commissioning / operation

⚠ WARNING

Risks related to moving parts!

Moderate injury, including severe flesh wounds, puncture wounds and severe bruising.

- ▶ Never reach into moving parts.

Risk of break-up during operation!

Death or severe injury.

- ▶ Do not expose the product to any mechanical loads under any circumstances.

Risk of electrical shocks through touching live parts!

Death or serious injury.

- ▶ Before working on the electrical equipment, switch off the power supply and secure it against being switched on again.

The Smart Function Kit must not be put into service until it has been verified that the final product (for example a machine or system) into which the Rexroth product has been installed complies with the country-specific requirements, safety regulations and standards for the application.

⚠ CAUTION

Hot surfaces with temperatures above 60 °C.

Risk of burns

- ▶ Do not touch hot surfaces.
- ▶ If required, install a guard to prevent accidental contact.
- ▶ Protect from burns by wearing appropriate protective clothing, e.g. heat-resistant gloves.

Increased noise build-up!

Continuous exposure can lead to damage to hearing.

- ▶ If excessive noise is generated, wear ear protectors and check for any damage.

Slipping on escaping lubricants!

Slipping.

- ▶ Take suitable precautions to collect any escaping lubricant and dispose of it in the proper way.

Initial commissioning

The system must be fully pre-wired and powered on for initial commissioning. After powering on, the system takes approximately 100 seconds to power up completely.

- ▶ Ensure that your HMI terminal device or a commissioning PC is connected to the network of the Smart Function Kit (⇒ 7.5 "Connection of the HMI terminal device").
- ▶ Check the network settings of your HMI terminal device (⇒ 7.5 "Connection of the HMI terminal device").
- ▶ Open your web browser and enter the IP address of the Smart Function Kit (standard: 192.168.0.1). The web browser will now automatically connect to the Smart Function Kit.
- ▶ Depending on the security settings of your web browser and on the browser, a security warning to be confirmed will appear during connection establishment.
- ▶ Depending on the configuration of the browser, deleting its cache is necessary.

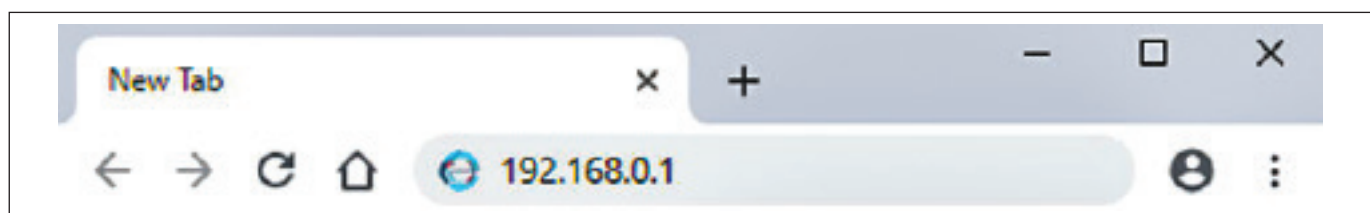

Fig. 19: Entering the IP address

8.1 Checking the operating conditions

Observe ambient temperature, load, travel speed and stroke ➡ "Table 26: Normal operating conditions" on page 36.

8.2 Commissioning (trial run, running in)

NOTICE

Malfunction of the product!

Damage to the product.

- ▶ Only start up the product after running successful tests under simulated production conditions.
- ▶ Move at low speed over the entire stroke.
- ▶ Optimize the interaction of the mechanical system and the electronics.

8.3 Operation

NOTICE

Escaping lubricants and anti-corrosion medium

Damage to the environment.

- ▶ Take suitable precautions to collect any escaping lubricant and dispose of it in the proper way.

For further information for operation of the system ➡ "Smart Function Kit Software" instructions.

9 Maintenance and care

9.1 Cleaning and care

NOTICE

Risk of damage due to improper cleaning, e.g. use of solvents and high-pressure jets!

Degradation of seals and functional failure of the product.

- ▶ Do not use high-pressure cleaning equipment.
 - ▶ For cleaning, use only water and, if necessary, a mild detergent.
- ▶ Before cleaning, seal all holes with suitable protective caps/devices.
 - ▶ Check that all seals and locks of plug connections are fitted tightly to ensure that no moisture can penetrate into the product during cleaning.

9.2 Regular maintenance work

- ▶ Check all plug and clamping connections of the components at least once a year for proper fit and damage.
- ▶ Check possible cable breaks and crushed lines.
- ▶ Damaged parts must be exchanged immediately.

9.3 CMOS battery industrial PC PR21

The CMOS battery has a service life of approx. 5 years, depending on the environmental conditions and the usage scenario. The service life can be significantly reduced if there are frequent or long interruptions in the power supply (e.g. when the system is switched off, during storage).

- ▶ A preventive exchange after 2 years is recommended, even if the actual service life can be significantly longer

For battery change, observe the instructions in the PR21 product manual.

The CMOS battery is available from Bosch Rexroth under the material number R911401323.

9.4 Maintenance of the force sensor

The force sensor is maintenance-free.

The technical specifications of the sensor are valid for 10 million measurement cycles.

The manufacturer may check and calibrate the sensor. In this case, please contact the Bosch Rexroth service.

9.5 Lubrication of the electromechanical cylinder EMC

Observe the instructions in the product manual "Electromechanical cylinder EMC" and/or "Electromechanical cylinder EMC-HP".

Always when the specified travel range has been covered.

- ▶ For special operating conditions (e.g., special type of end fixity, dust, solvents, etc.), the lubricants must be adapted to the application.
- ▶ Under normal operating conditions, the system must be relubricated **at least every 2 years** (aging of grease), or when the specified travel range has been covered.

⚠ CAUTION

Contact with escaping lubricants and anti-corrosion medium.

Irritation or redness of the affected skin area

- ▶ Use appropriate protective equipment to protect against contact with any lubricants or anti-corrosion medium.
- ▶ Observe safety data sheet of the lubricant used.

Lubrication of the Smart Function Kit is restricted to lubrication of the ball screw assembly using a conventional manual grease gun or for greasing option LCF with a central lubrication system with semi-fluid grease.

Basic lubrication is carried out by the manufacturer. Initial lubrication is only necessary for lubrication option LPG.

For lubrication ➡ Observe the instructions in the product manual "Electromechanical cylinder EMC" and/or "Electromechanical cylinder EMC-HP".

1. In order to reach lubrication position L_{Lub} , move to position S as per table. The prerequisite is that the system zero point corresponds to the standard settings. The Zero point (0) is at 3 mm from the fixed stop (Z). If the system zero point was shifted to a different position in the software, this shift must be taken into account when calculating position S.
2. Apply grease to the ball screw assembly via the lube nipple. Apply the entire relubrication quantity in one go as per Table 26.
3. Extend and retract the piston rod over its entire travel range for three full cycles.

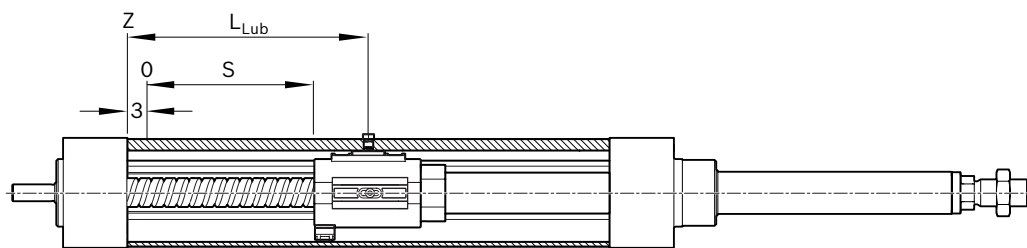

Fig. 20: Lubrication position

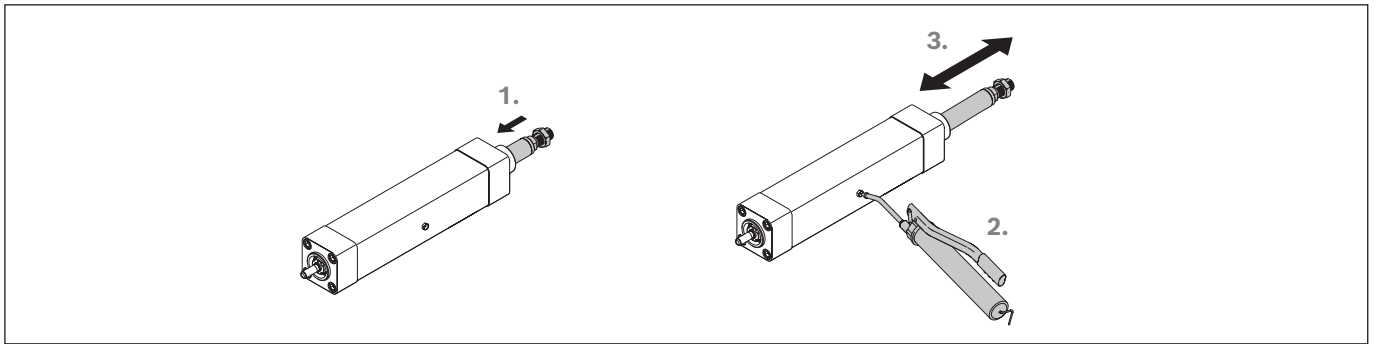

Fig. 21: Lubricating the EMC

Table 25: Relubrication

EMC	P (mm)	S (mm)	Relubrication interval (km)	Relubrication quantity (cm ³)
EMC 40 / SPK 002	5	$13.1 + s_{max}/2$	250	0.8
	10	$14.5 + s_{max}/2$	500	1.1
	16	$12.0 + s_{max}/2$	800	1.5
EMC 50 / SPK 004	5	$7.0 + s_{max}/2$	250	1.2
	10	$7.0 + s_{max}/2$	500	1.9
	20	$7.0 + s_{max}/2$	1 000	3.0
EMC 63 / SPK 007	5	$7.0 + s_{max}/2$	250	1.9
	10	$7.0 + s_{max}/2$	500	2.3
	25	$7.0 + s_{max}/2$	1 250	4.2
EMC 80 / SPK 012	5	$7.0 + s_{max}/2$	250	2.7
	10	$4.5 + s_{max}/2$	500	3.8
	20	$4.5 + s_{max}/2$	1 000	4.3
	32	$4.5 + s_{max}/2$	1 600	6.7
EMC 100 / SPK 019	5	$4.9 + s_{max}/2$	250	3.7
	10	$7.5 + s_{max}/2$	500	8.2
	20	$1.5 + s_{max}/2$	1 000	10.6
	40	$1.5 + s_{max}/2$	2 000	17.5
EMC 100XC / SPK 030	10	$12.3 + s_{max}/2$	100	13.2
	20	$15.4 + s_{max}/2$	200	12.4
EMC-130-HP / SPK 045	5	72	150	$20 + s_{max}/60$
	10	72	300	$20 + s_{max}/60$
EMC-160-HP / SPK 070	5	72	150	$29 + s_{max}/50$
	10	72	300	$29 + s_{max}/50$

P = Screw lead

 s_{max} = Max. travel distance of the EMC (from the order configuration)

10 Disposal

10.1 Return

Products manufactured by us can be returned free-of-charge for disposal. However, a prerequisite for this is that there are no objectionable films such as oil, grease or other contamination on the device. Moreover, the device must be free of inordinate foreign materials and / or components.

Please send the products carriage paid to the following address:

Bosch Rexroth AG
Linear Motion Technologies
Ernst-Sachs-Straße 100
97424 Schweinfurt

10.2 Packaging

Packaging materials consist of cardboard, wood, and expanded polystyrene. They can be easily recycled at any point of acceptance. For ecological reasons, please refrain from returning the packaging.

10.3 Product

The product and its components must be disposed of correctly and in compliance with all applicable national and international guidelines and regulations. Collect any leaking lubricant and dispose of it correctly.

10.4 Batteries and accumulators



Batteries and accumulators can be marked with this symbol. The symbol of the crossed-out waste bin on wheels indicates that batteries are to be collected separately. Within the EU, the end user is legally obliged to return used batteries. The relevant regulations must be observed outside of the validity of the EU Directive 2006/66/EC. Used batteries may contain toxic substances that can harm the environment or human health if not stored or disposed of properly. The batteries or accumulators contained in Rexroth products are to be properly disposed after use, according to the country-specific return systems.

10.5 Recycling

Due to the high metal content, the products can mostly be recycled. To achieve an optimum metal recovery, dismantling into individual assemblies is required.

11 Service and support

We have a dense global service network for fast and optimal support. Our experts will be happy to assist you in any way they can. You can reach us 24/7 – even on weekends and holidays.

Service Germany

You can reach our service hotline and our service helpdesk under:

Phone: +49 9352 40 5060

Fax: +49 9352 18 4941

E-mail: Service@boschrexroth.de

Internet: <http://www.boschrexroth.com>

Supplementary notes on service, repair work (e.g. delivery addresses) and training can be found on our website.

Worldwide service

If you are located outside of Germany, please first contact your local service representative. For hotline numbers, please refer to the sales addresses online.

Information preparation

We will be able to help you quickly and efficiently if you have the following information ready:

- A detailed description of the malfunction and conditions
- Information on the name plate of the affected product, particularly the type code and serial numbers
- Your contact information (phone and fax number and email address)

12 Operating conditions

Observe the information on the environmental and operating conditions as stated in the product catalogs. Otherwise, a function and safety warranty cannot be assumed generally. For special environmental conditions, please consult us.

Table 26: Normal operating conditions

Operating conditions	Value (max.)	Unit
Storage ambient temperature	-20 ... +55	°C
Operation ambient temperature:		°C
- EMC cylinder	-10 ... +50	
- Force sensor	-10 ... +50	
- MS2N motor	0 ... +50 (loss of performance from +40)	
- HCS01 drive controller	0 ... +50 (loss of performance from +40)	
- PR21 industrial PC	0 ... +50	
Travel speed	0.3 – 0.5 (depending on the version)	m/s
Acceleration	12 ... 50 (see EMC catalog)	m/s ²
Minimum travel range	> s _{min} (see EMC catalog)	mm
Maximum travel range	400 (optionally up to 1,500 possible)	mm
IP protection class:		
- EMC cylinder	IP54 (IP65 as an option)	
- Force sensor	IP67 (only with connected cable)	
- MS2N motor	IP64	
- HCS01 drive controller	IP20	
- PR21 industrial PC	IP40	

12.1 Tightening torques

Screws of strength class 8.8 are used as standard. Any deviations are marked accordingly.

Table 27: Tightening torques

 8.8	M2	M2.5	M3	M4	M5	M6	M8	M10	M12
M_A max (Nm) μ = 0.125	0.4	0.7	1.3	2.7	5.5	9.5	23	46	80

Bosch Rexroth AG
Ernst-Sachs-Straße 100
97424 Schweinfurt, Germany
Tel. +49 9721 937-0
Fax +49 9721 937-275
www.boschrexroth.com

Find your local contact person here:

www.boschrexroth.com/contact



Subject to modifications

© Bosch Rexroth AG 2025

Printed in Germany
R320103194/2026-04